

PROJECT	TYPE	NOTES
---------	------	-------

OVERVIEW

The SW-UNV-5 brick light is a recessed fixture designed to illuminate steps and walkways. The die-cast housings and trims are both made from zinc alloys for excellent corrosion resistance. This fixture was designed for durability and comes with a 5 year warranty.



TECHNICAL SPECIFICATIONS

Operating Voltage	100-277VAC
Power Consumption	5W
Lumens (3000K)	74-312lm
Color Temperature	3000K, 4000K (2700K, 3500K, TF AMBER)
CRI	90+
LED Life	50,000 hrs
Housing Material	Die-cast zinc aluminum
Lens Material	Tempered Glass
Trim Material	Die-cast zinc magnesium
Trim Finishes	Black, Brushed Steel, White
Hardware	304 Stainless Steel (tamper resistant)
Warranty	5 years



DIMENSIONS

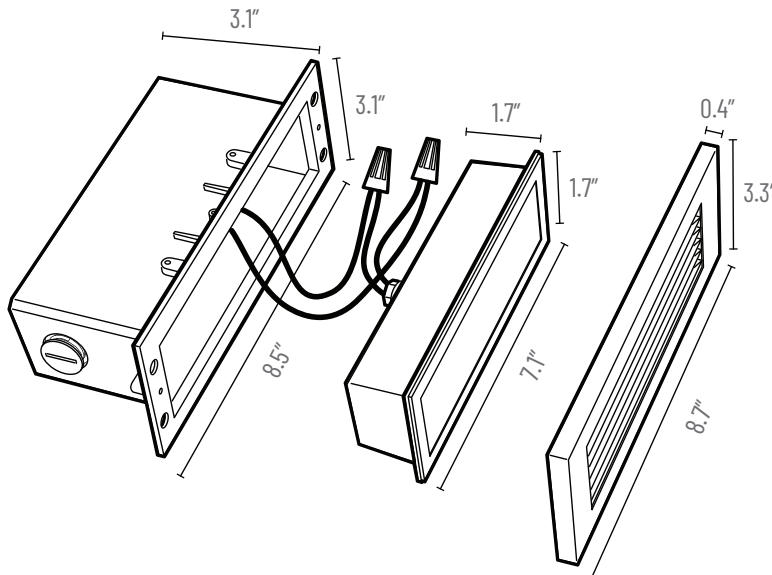

HOUSING ACCESSORIES



Masonry Brackets



Stud Brackets



Spring Clips

ORDER CODE

TRIM & LIGHT ENGINE

SW-UNV-5	-	-	-
----------	---	---	---

TRIM

- FL - Flat
- LV - Louvered
- R - Recessed

FINISH

- BL - Black
- BS - Brushed Steel
- WH - White

CRI / CCT

- 930 - 90+ / 3000K
- 940 - 90+ / 4000K
- XXX - Custom

HOUSING

SW-UNV-5	H	-
----------	---	---

MOUNTING ACCESSORIES

- None
- MB - Masonry Brackets
- SB - Stud Brackets
- SC - Spring Clips

